

CRYSTALVUE™ PUBLIC VIEW DISPLAY

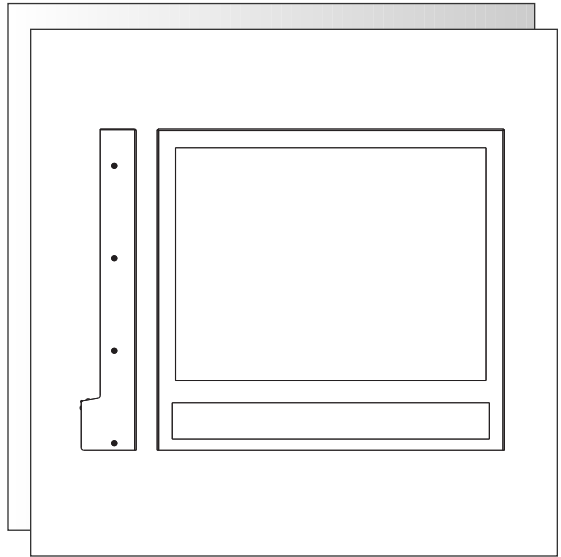

PVD20 IP Series

SAFETY PRECAUTIONS

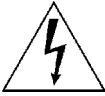

CAUTION
RISK OF ELECTRIC SHOCK. DO NOT OPEN!



CAUTION: TO REDUCE THE RISK OF ELECTRICAL SHOCK, DO NOT OPEN COVERS. NO USER SERVICE-ABLE PARTS INSIDE. REFER SERVICING TO QUALIFIED SERVICE PERSONNEL.

This label may appear on the bottom of the unit due to space limitations.



The lightning flash with an arrowhead symbol within an equilateral triangle is intended to alert the user to the presence of uninsulated "dangerous voltage" within the product's enclosure that may be of sufficient magnitude to constitute a risk of electric shock to persons.



The exclamation point within an equilateral triangle is intended to alert the user to presence of important operating and maintenance (servicing) instructions in the literature accompanying the appliance.

WARNING: TO PREVENT FIRE OR SHOCK HAZARD, DO NOT EXPOSE UNITS TO RAIN OR MOISTURE.



Attention: Installation should be performed by qualified service personnel only in accordance with the National Electrical Code or applicable local codes.

24 VAC Units: Do Not Exceed 30 VAC Input. Voltage applied to the unit's power input should not exceed 30VAC. Normal input voltage is 24 VAC. User supplied wiring from 24 VAC supply to unit must be in compliance with electrical codes (Class 2 power levels). Do not ground 24 VAC supply at power supply terminals or at unit's power supply terminals.

SECURITE



ATTENTION

RISQUE D'ÉLECTROCUTION.
NE PAS OUVRIR



DANGER: POUR ÉVITER TOUT RISQUE D'ÉLECTROCUTION, NE PAS OUVRIR LE BOÎTIER. IL N'Y A PAS DE PIÈCES REMPLAÇABLES À L'INTÉRIEUR. POUR TOUTE RÉVISION, S'ADRESSER À UN TECHNICIEN SPÉCIALISÉ.

En raison de limitation de place, cette étiquette peut être placée sur le dessous de l'appareil.



L'éclair fléché dans un triangle équilatéral, avertit l'utilisateur de la présence d'une "tension dangereuse" non isolée à l'intérieur de l'appareil et d'une valeur suffisante pour constituer un risque d'électrocution.



Le point d'exclamation contenu dans un triangle équilatéral, avertit l'utilisateur de la présence, dans la documentation qui accompagne l'appareil, de consignes d'utilisation et de maintenance importantes.

ATTENTION: POUR ÉVITER LE RISQUE D'ÉLECTROCUTION OU D'INCENDIE, NE PAS EXPOSER À LA PLUIE OU À L'HUMIDITÉ UN APPAREIL.



Attention: L'installation doit être effectuée uniquement par du personnel de service qualifié conformément à la réglementation du Code Electrique National ou à la réglementation locale.

Appareils 24 VCA

Ne pas excéder 30 VCA. La tension appliquée à l'entrée d'alimentation de l'appareil ne devrait pas excéder 30 VCA. Toute installation électrique fournissant du 24 Volts courant alternatif doit être conforme aux codes électriques. (Niveaux d'alimentation de la Classe 2). Ne pas brancher une prise de terre sur les bornes d'alimentation 24 Volts ou aux bornes d'alimentation de l'appareil.

SICHERHEITSVORKEHRUNGEN



VORSICHT

STROMSCHLAGGEFAHR!
BITTE NICHT ÖFFNEN!



VORSICHT: UM EINEN ELEKTRISCHEN SCHLAG ZU VERMEIDEN, ABDECKUNG NICHT ENTFERNEN. WARTUNGEN ALLER ART QUALIFIZIERTEM PERSONAL ÜBERLASSEN.

Aus Platzgründen kann diese Warnung auf der Unterseite des Gerätes angebracht sein.



Das Blitzsymbol im gleichseitigen Dreieck soll den Benutzer auf nicht isolierte "Hochspannung" im Gehäuse aufmerksam machen, die eventuell stark genug ist, um einen elektrischen Schlag zu verursachen.



Das Ausrufezeichen im gleichseitigen Dreieck soll den Benutzer auf wichtige Bedienungs- und Wartungsanleitungen in der dem Gerät beigefügten Literatur aufmerksam machen.

WARNUNG: UM FEUER ODER ELEKTRISCHE SCHLÄGE ZU VERMEIDEN, SETZEN SIE DAS GERÄT NIEMALS REGEN ODER FEUCHTIGKEIT AUS.



Achtung! Die Installation sollte nur von qualifiziertem Kundendienstpersonal gemäß jeweilig zutreffender Elektrovorschriften ausgeführt werden.

24 VAC Geräte

Achtung! 30 Volt Eingangswechselfspannung darf für 24 VAC Modelle nicht überschritten werden. Normal-betrieb findet bei 24 Volt Wechselfspannung statt. Die Kabel- bzw. Drahtverbindung vom Netzgerät zu dem vor-liegenden Gerät muß die Bestimmungen der Schutz-klasse II erfüllen. Nicht die 24-Volt-Leitung erden weder am Netzgerät noch an den Anschlußklemmen des vor-liegenden Gerätes

PRECAUCIONES DE SEGURIDAD



PRECAUCION

RIESGO DE CHOQUE
ELECTRICO. ¡NO ABRIR!



PRECAUCION: PARA REDUCIR EL RIESGO DE CHOQUE ELÉCTRICO, FAVOR NO ABRIR LA CUBIERTA. ESTE EQUIPO NO CONSTA DE PIEZAS O PARTES QUE REQUIEREN SERVICIO O MANTENIMIENTO. PARA REPARACIONES FAVOR REFERIRSE A UN TÉCNICO CALIFICADO.

Debido a limitaciones de espacio, esta etiqueta puede aparecer en la parte inferior de la unidad.



El símbolo representado por un relámpago con punta de flecha dentro de un triángulo equilátero, se muestra con el objetivo de alertar al usuario que existen "voltajes peligrosos" sin aislamiento, dentro de la cubierta de la unidad. Dichos voltajes pueden ser de tal magnitud que constituyen un riesgo de choque eléctrico a personas.



El símbolo de exclamación dentro de un triángulo equilátero, se muestra con el objetivo de alertar al usuario de que instrucciones de operación y mantenimiento importantes acompañan al equipo.

PELIGRO: PARA EVITAR EL PELIGRO DE INCENDIO Ó CHOQUE ELÉCTRICO, NO EXPONGA A LA LLUVIA Ó HUMEDAD.



Atención: La instalación de este equipo debe ser realizada por personal capacitado, solo en acuerdo, y en cumplimiento de normas del "National Electric Code" (Código Eléctrico Nacional) ó las normas del Gobierno Nacional Local.

Unidades de 24 VCA

No exceder 30 VCA de entrada. Voltage suplido a la unidad no debe exceder 30 VCA. Voltage de entrada normal es de 24 VCA. El cableado de 24 VCA provisto por el usuario debe cumplir con las normas eléctricas (Clase 2 de niveles de alimentación). No conectar los 24 VCA a tierra en las terminales de la alimentación ó a las terminales de la fuente de alimentación de la unidad.



ATTENTION – Observe Precautions For Handling Electrostatic Sensitive Devices

What is Electrostatic Discharge?

A transfer of electrostatic charges between bodies at different electrostatic potentials caused by direct contact or induced by an electrostatic field. The following are some examples of electrostatic charges:

1. Walking across a nylon carpet on a dry day generates a static electrical charge of 35,000 volts.
2. Opening a plastic bag generates a charge of 20,000 volts.

Warning: In a domestic environment, this product may cause radio interference in which case the user may be required to take adequate measures.

TABLE OF CONTENTS

1	UNPACKING	8
2	SERVICE	8
3	DESCRIPTION	8
4	INSTALLATION	8
	4.1 Mounting	8
	4.2 Power and Video Connections	8
	4.3 IP Connections	8
	4.3.1 Connecting the RJ-45 IP Connection	8
5	PVD20 SET UP	10
	5.1 Verify Operations	10
	5.2 Accessing the Control Board	
	Configurations and Option Switches	10
	5.3 Detail of Options Switches	11
	5.4 RS232 Control Options	12
	5.5 Monitor Set Up	12
	5.5.1 Using the Remote Control	12
	5.5.2 On Screen Display	
	Using the Remote Control	13
	5.5.3 On Screen Display	
	Main Menu Selections	13
	5.5.4 On Screen Display	
	Sub Menu Selections	13

TABLE OF CONTENTS (CONT.)

5.6 Internal Monitor Controls	15
5.7 Flash Memory Set Up	15
5.7.1 Activate the Flash Memory Card ...	15
5.8 Camera Adjustments	16
5.8.1 Color High Resolution Series Camera	16
5.8.2 Wide Dynamic Range (WDR) Series Camera	16
5.9 Camera and Lens Settings	17
5.9.1 Dip Switch Location for Color High Resolution Camera	17
5.9.2 Dip Switch Location for Wide Dynamic Range (WDR) Camera	18
5.10 Focusing the Camera	18
6 TROUBLESHOOTING	19
6.1 Flickering Screen	19
6.2 No Video Displayed on Screen	19
7 SPECIFICATIONS	20
7.1 System Specifications	20
7.2 Mechanical Specifications	21
7.3 Environmental	21
7.4 Camera Specifications	21
7.4.1 Color High Resolution	21
7.4.2 Wide Dynamic Range (WDR)	22
7.5 Lens Specifications	22
7.5.1. Color High Resolution	22
7.5.2. Wide Dynamic Range (WDR)	22
8 PVD ACCESSORIES	23
8.1 Power Supplies	23
8.2 Mounting Options	23
8.3 Sign Hanging Hardware	23
9 REPLACEMENT PARTS	24
10 DIMENSIONAL OUTLINE	24

1. UNPACKING

Unpack carefully. This is an electromechanical device and should be handled carefully. Remove all of the items from the box. It is recommended that you do not remove the clear protective plastic covers on the PVD20 at this time. Check to ensure that the following items are included:

- PVD20: LCD Monitor
- Remote Control with 2 AAA Batteries (remote is located in a pocket in the foam padding)

Note: Set aside the remote for later use.

2. SERVICE

If the unit needs repair service or parts contact Aigis Mechtronics for authorization to return as well as shipping instructions.

3. DESCRIPTION

The PVD20 Series consists of a 20.1" LCD Monitor with a high resolution color camera or a wide dynamic range camera.

Construction/Finish: Fabricated aluminum case.

4. INSTALLATION

Attention: Installations should be performed by qualified service personnel only in accordance with the National Electrical Code or applicable local codes.

4.1 Mounting

The PVD20 is available in a variety of mount configurations. For specific directions on mounting the PVD20 unit see the Instruction Book that came with your mount. Once the PVD20 is mounted, the installation procedure may continue.

4.2 Power and Video Connections

Attach the 2 24VAC power connections to your transformer/power supply. If you have an external video source you would like to use as your auxiliary source, connect it to the cable "Video In".

4.3 IP Connection

4.3.1 Connecting the RJ-45 IP Connection

Located on the back of the PVD20 is the RJ-45 Ethernet connection. See **Figure 1** for location. Use this to access the CCTV video from the PVD20 over the network.

The internal network card connects to the network via a standard network cable, and automatically detects the speed of the local network segment. (10BaseT/100BaseTX Ethernet).

To access the video via the network use the following information.

User: Root

Password: Pass

For more information on functionality and features please go to: www.axis.com and find information on the AXIS 282.

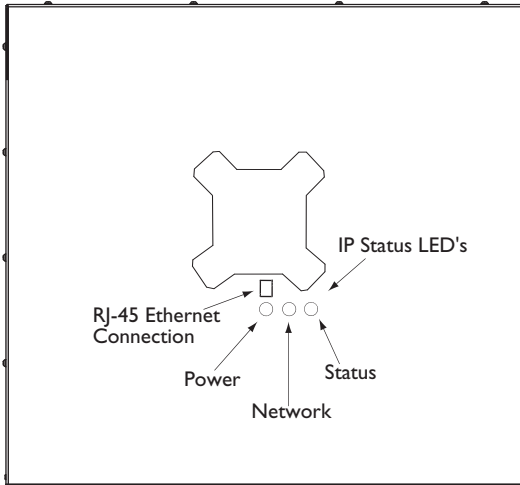

Figure 1: PVD20 Back View

The multi-colored Status, Network, and Power indicators (LED's) flash as follows:

Status	Unlit	When Configured for "no Flash" on Camera access.
	Green	Steady for normal operation. Can be configured to flash green at intervals whenever the camera is accessed. See the online help for more information.
	Amber	Steady during startup, reset to factory default or when restoring settings.
	Red	Slow flash for failed upgrade.
Network	Unlit	No connection
	Green	Steady for connection to a 100 Mbit/s network. Flashes for network activity.
	Amber	Steady for connection to a 10 Mbit/s network. Flashes for network activity.
	Red	Flashes rapid red for hardware error, together with the Status indicator.
Power	Green	Normal operation
	Amber	Flashes green/amber during firmware upgrade

5. PVD20 SET UP

5.1 Verify Operations

Once the unit is powered the PVD20 is automatically activated.

At this time it is advisable to access the control board to verify the operation of the PVD20 and to make any adjustments needed to the Option Switches.

5.2 Accessing the Control Board Configurations and Option Switches

The Control Board is a microprocessor-based circuit that controls the on-board sensors and a two channel video switcher. The main purpose of this switcher is to select the on-board camera for display when motion has been detected. It may also be directed to ignore the sensor and select one of the two video signals or simply switch between the two at settable dwell rates.

To access the control board to verify operations do the following:

1. Remove the protective covers from the front of the unit.
2. Unscrew the two bottom screws on the back of the unit to access the area containing the camera and the control board.

Located on the control board to the left of the camera are the Control Board LED's. See **Figures 2, 3 & 4.**

3. Verify that the "Power LED" is Green signifying the PVD20 is on.
4. The "System Pulse LED" will be dull red showing the control board is running.
5. The "Camera On LED" is lit when the camera input is selected and off when the auxiliary input is selected.
6. If any of the above cannot be verified see **Section 6 Troubleshooting.**
7. For details on Option Switches see **Section 5.3 Option Switches.**

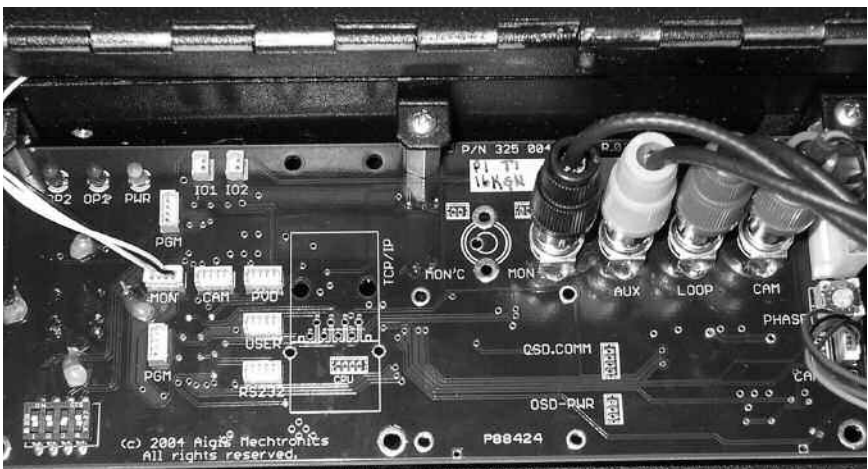

Figure 2: Control Board

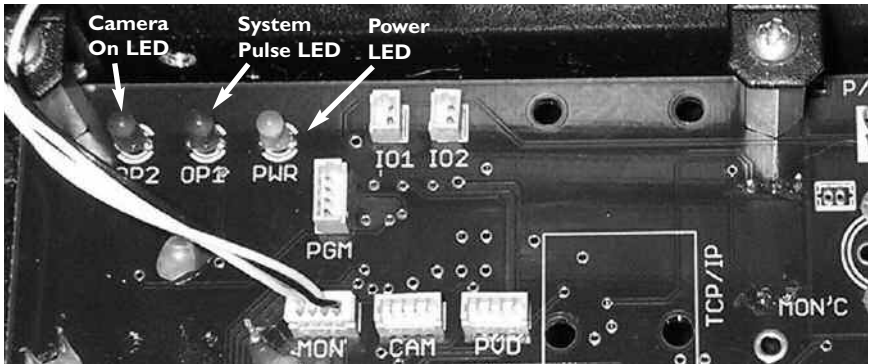

Figure 3: Control Board LED's

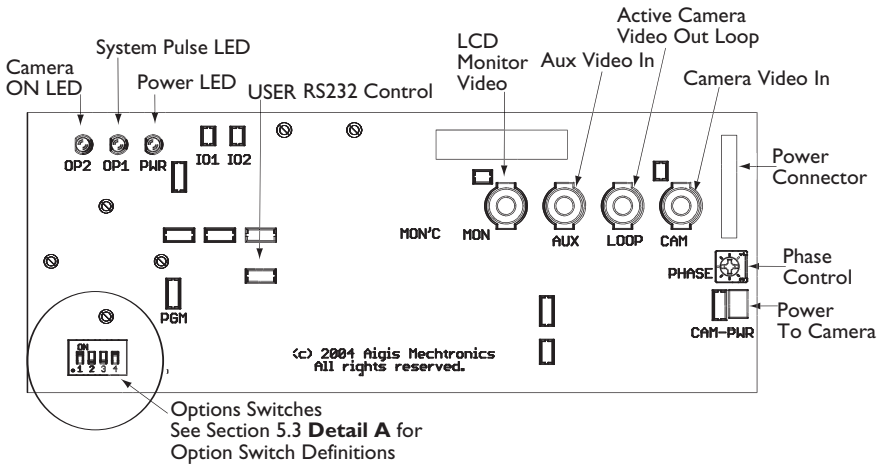
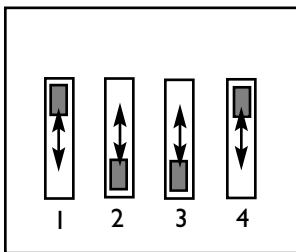

Figure 4: Control Board Configuration

5.3 Detail of Options Switches

Options may be controlled via the four “Options Switches” See **Figure 4** for locations, see **Detail A** for their respective functions.

Detail A



Note: is factory set up

1	Motion Switcher	ON	Enable Motion Switcher
		OFF	Disable Motion Switcher
2	Not Used	ON	Not used
		OFF	Not used
3	Synchronization Mode	ON	Sync to Aux Video
		OFF	Sync to Line
4	Light Sensor	ON	Enable Light Sensor
		OFF	Disable Light Sensor

5.4 RS232 Control Options

The operation of the control board may be modified via the USER RS232 Control port. See **Figure 4** for location. This port operates at 9600 baud 8E1, no flow control and cannot be changed. Any standard terminal may be connected and a '?' entered to get the control menu.

Note: The Aigis PVD20 is an advanced microprocessor controlled unit and has many options and operating modes that can be set up via the PVD20 communications port. It is not necessary to connect to this port to operate the PVD20 unit and is offered only as an OPTIONAL feature. To make any OPTIONAL configuration changes refer to the **PVD20 Advanced RS232 Set Up Instruction Book**, shipped with the RS232 connector or available online at www.aigismech.com.

5.5 Monitor Set Up

5.5.1 Using the Remote Control

The following section will define the remote control uses and explain the terms used when using the remote.

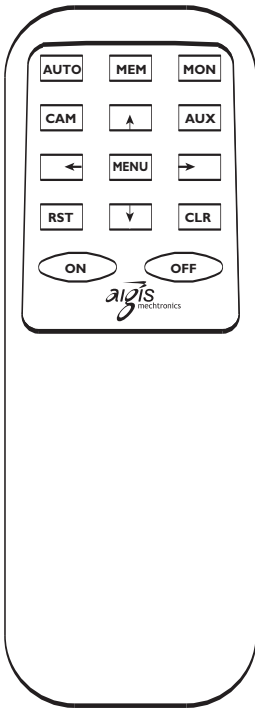

KEY TO REMOTE CONTROL

AUTO : Enables PIR switch upon motion from Auxiliary (default) to CCTV video

MEM : Records current setting

MON : Enters into Monitor Set Up mode and activates the on screen display (OSD)

CAM : Displays video from CCTV Camera (Disables switch upon motion from CCTV video to auxiliary video)

↑ : Moves cursor up when Menu is displayed

AUX : Displays auxiliary video (Disables switch upon motion from aux to CCTV video)

← : Moves cursor left when Menu is displayed

MENU : Activates the on screen display (OSD)

→ : Moves cursor to the right when Menu is displayed

RST : Reserved for future use

↓ : Moves cursor down when Menu is displayed

CLR : Clears keystrokes

ON : Turns unit on

OFF : Turns unit to stand-by mode

5.5.2 On Screen Display (OSD) Using the Remote Control

Any needed adjustments to the Monitor are made by navigating through the menus and sub menus with the remote control. To use the remote control to navigate the set up menus do the following:

1. Power on the unit by pressing the **ON** button on the remote control if the unit is not already on.
2. Press the **Menu** button on the remote control to activate the **On Screen Display (OSD)**.
Use ← and → to navigate the main menu.
Use ↑ and ↓ to navigate the sub-menu.
Use → to select a function from the sub-menu.

5.5.3 On Screen Display Main Menu Selections

- VIDEO
- OSD (ON SCREEN DISPLAY)
- MISC.
- AUDIO (NOT APPLICABLE TO THIS UNIT)
- INPUT SELECT

5.5.4 On Screen Display Sub-Menu Selections

MAIN MENU •VIDEO

Sub Menu	Sharpness	0-100
	Brightness	0-100
	Backlight	0-100
	Contrast	0-100
	Color	0-100
	Tint	0-100

MAIN MENU • OSD (ON SCREEN DISPLAY)

- Sub Menu Horizontal Position 0-100
Pressing the ← arrow moves the OSD left.
Pressing the → arrow moves the OSD right.
- Vertical Position 0-100
Pressing the ← arrow moves the OSD down.
Pressing the → arrow moves the OSD up.
- Blending 0-100
Pressing the ← arrow makes the OSD more Opaque.
Pressing the → arrow makes the OSD more transparent
- Duration 0-60
The amount of time that the OSD is displayed (in seconds).
- Language
English, Espanol, Francais, Deutsch, Italiano

MAIN MENU • MISC

- Sub Menu Information
Gives unit information
- Factory Preset
Resets to Factory Setting Default
- Mirroring
Display and OSD will have a mirror image
- Upside Down
Turns display and OSD 180° Display Aspect
Not applicable to this unit

MAIN MENU • INPUT SELECT

- Sub Menu RGB, DVI, Video, S-VHS, YpbPr

5.6 Internal Monitor Controls

Note: It is recommended to use the Remote Control to set up the unit. See section 5.5.1 through 5.5.4 for set up using the remote control.

If the Remote Control is not available do the following to set up the PVD20.

1. If the unit is not already powered, press the power button on the monitor control panel. See **Figure 5** for exact location.
2. Make any needed adjustments to the monitor from the menu button. See **Figure 5** for exact location and uses.

Menu: Use this button to call up the menu on the monitor. Use the select, scroll down and scroll up to navigate within the menu. Make adjustments to the monitor from the menu.

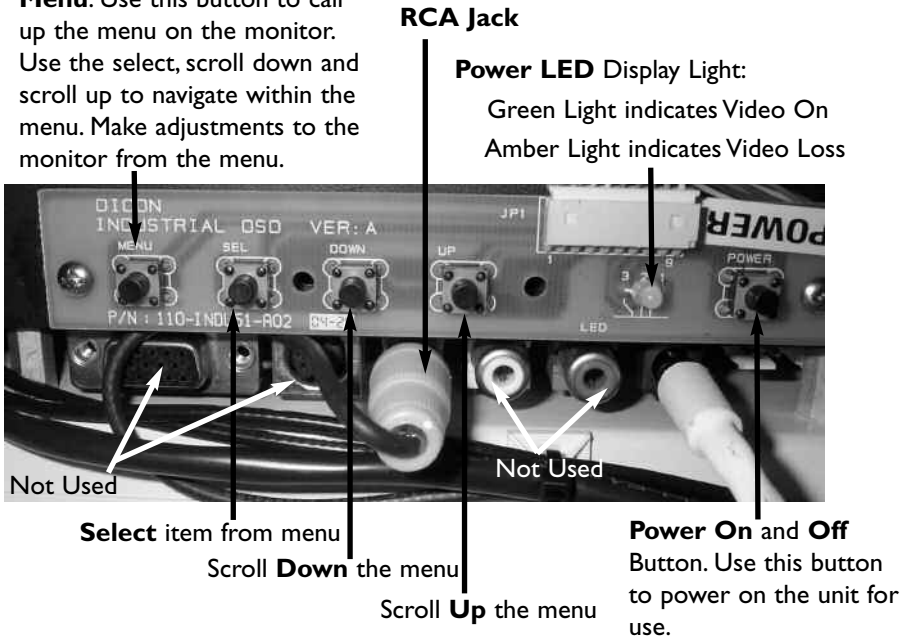

Figure 5: Monitor Controls

5.7 Flash Memory Set Up

5.7.1 Activate the flash memory card.

1. If the unit is supplied with a flash memory device it will be wired into the AUX Video Input. Insert a SD memory card with a base line JPG image in its root directory to activate the image on the card. The unit will automatically display the JPG image when AUX is selected for display.
2. If more than one JPG is on the card, the PVD20 will display a slide show rotating through all supplied JPG images.
3. Some units may be supplied with a JPG remote control which will allow additional features to be controlled. Use this remote and follow the on screen display, for set up.

5.8 Camera Adjustments

Refer to the following sections to set up the camera for operation. The camera module position can be adjusted both vertically and horizontally and can also be rotated for proper tilt orientation.

See **Figures 6** or **7** for the correct camera series adjustment points.

5.8.1 Color High Resolution Series Camera

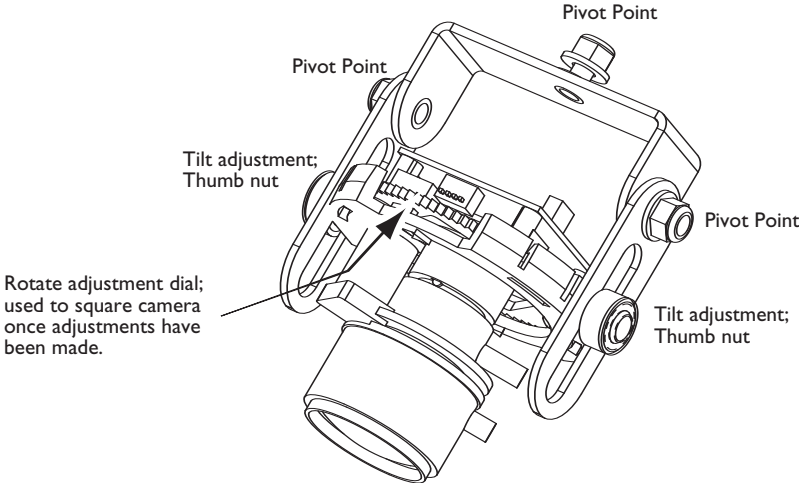

Figure 6: Color High Resolution Camera Adjustment Points

5.8.2 Wide Dynamic Range (WDR) Series Camera

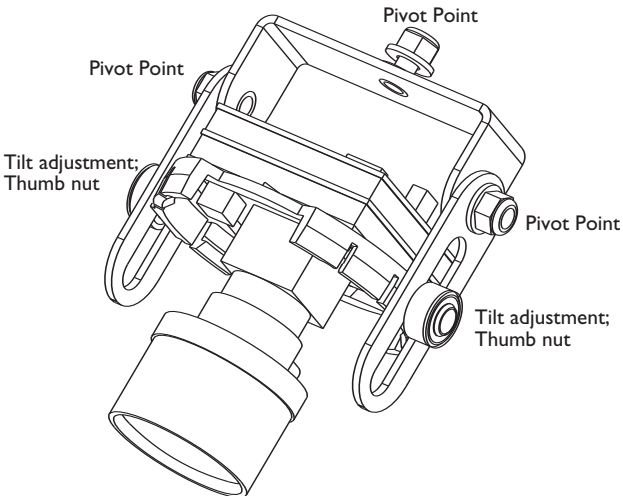

Figure 7: Wide Dynamic Range (WDR) Camera Adjustment Points

5.9 Camera and Lens Settings

The camera module has various settings for any additional adjustments that may be required. See **Figure 8 or 9** for the correct camera series settings and dip switch locations.

5.9.1 Dip Switch Location for Color High Resolution Camera

See **Detail B** for dip switch information.

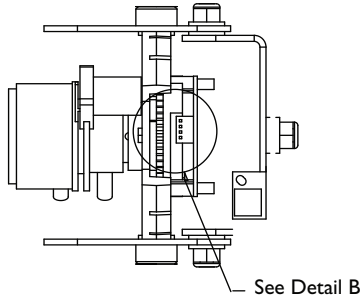

Figure 8: Dip Switch Location: Color High Resolution Camera

DETAIL B

The following chart diagrams the selectable dip switches and their respective functions for the Color High Resolution Camera:

IRIS	FL	BLC	Sync
DC	ON	ON	INT
1	2	3	4

Note: is factory set up

1	IRIS	DC	DC IRIS
		AES	AES
2	Flickerless (FL)	ON	Shutter speed to be fixed at 1/100 sec.
		OFF	Normal position
3	Backlight Compensation (BLC)	ON	Set to this position when a strong light is in the back ground.
		OFF	Normal position
4	Synchronization Mode	INT	Internal Synchronization mode
		L.L.	Line lock mode

5.9.2 Dip Switch Location for Wide Dynamic Range (WDR) Camera

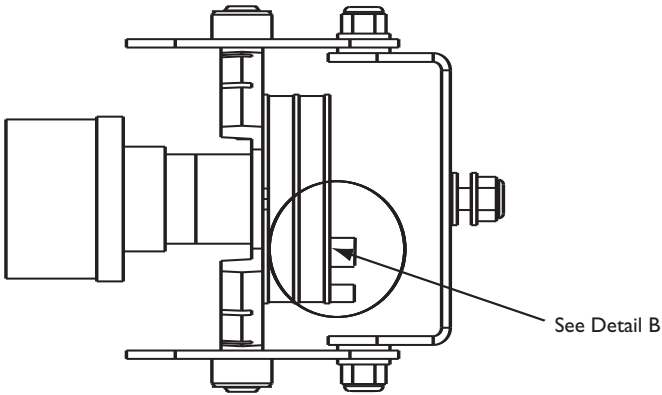

**Figure 9: Dip Switch Location:
Wide Dynamic Range (WDR) Camera**

DETAIL C

The following diagram shows the selectable dip switches for the Wide Dynamic Range (WDR) Camera:

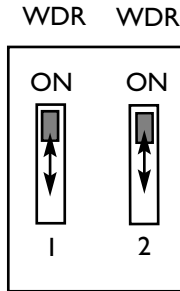

Note:  is factory set up

5.10 Focusing the Camera

Adjust the focus on the camera by adjusting the rings around the lens until the picture is sharp and clear. If the camera is going to be angled to one side or another, there is a sliding black mask behind the front “window” with a hole for the camera. Adjust the camera to the proper tilt position, see **Figures 6 or 7** for your camera series, and then slide the black mask until none of it shows in the picture.

6. TROUBLESHOOTING

6.1 Flickering Screen

If the screen is flickering, the most likely cause is a power supply issue. Ensure that there is proper AC voltage at the monitor. Running wires long distances from the power supply may cause undesirable voltage loss. For running power longer distances it is recommended that you use a heavier wire gauge. Refer to a copper wire table and line loss table for exact engineering specifications.

Below is a table of maximum distances you can go with specified wire gauges with a 24V transformer:

20 AWG 40 Feet	14 AWG 170 Feet
18 AWG 70 Feet	12 AWG 270 Feet
16 AWG 100 Feet	10 AWG 430 Feet

6.2 No Video Displayed on Screen

A. First check the unit to see if power is supplied.

B. If power is supplied to the unit:

Open the cover to the PVD20. Press “CAM” on the remote control.

Check the Monitor Controls “Power LED” (see **Figure 5** for location) to see if it is illuminated.

C. If the “Power LED” is not illuminated:

Press the Power button next to the “Power LED” to activate the unit. The “Power LED” will then be green indicating there is video going to the monitor.

D. If the “Power LED is amber:

Unplug the yellow “RCA Jack” (see **Figure 5** for location), and plug in an alternate video source in this location, such as a DVD player or test pattern generator. At this point if the alternate video source is detected, please contact Aigis Customer Service department for further instructions.

E. If the alternate video source is not detected:

Press “MENU” on the remote control. Press the left arrow “←” until you navigate to the “Input Select” menu. Using the down arrow “↓” navigate to “Video”, select it using the right arrow “→” as the input source. Check to see if video is displayed on the screen.

F. If video is displayed on the screen after doing (E.) above:

Press the Power button next to the “Power LED” See **Figure 5** for location, to turn the monitor off, this will save the settings. Press the Power button again to re-activate the unit.

G. If no video is displayed:

Contact Aigis Mechtronics Customer Service.

7. SPECIFICATIONS

7.1 System Specifications

Display Size	20.1"
Resolution	640H x 480V
Pixel Pitch	0.6375mm x 0.6375mm
Brightness	450 cd/m ²
Contrast Ratio	350 : 1
Viewing Angle	+/- 88 ° X,Y
Lamp Life	Over 50,000 Hrs
Video Input	2 Composite, S-Video
On Screen Display	Yes - Monitor Setup
Power Requirement	24 VAC 80W
Light Sensor	Display switches to Power Save mode upon light reduction;
Remote Control	On/Off; Monitor Setup; Video Input Selection - Aux/Camera;
2-Input Switcher	1- 59 sec A / B
Advanced Set Up	Via RS232 Port
Mounting	VESA Pattern 75mm and 100mm square patterns Threaded 10-24, 8 places



Not more than 3/8" of the screw can enter the unit or damage to the unit is possible.

Options

Motion Detection	Built-in PIR Motion detector switches unit from Aux to Camera upon activation
On-board Flash Memory	Content Format Support: JPEG (Baseline, up to 16 Megapixel), Compatible Flash Memory Card Formats: SD™, SmartMedia™ / Compact Flash™ / Memory Stick™

Maximum distances with specified wire gauges using a 24V transformer:

20 AWG: 40 Feet 18 AWG: 70 Feet 16 AWG: 100 Feet

14 AWG: 170 Feet 12 AWG: 270 Feet 10 AWG: 430 Feet

7.2 Mechanical Specifications

Housing

Construction	Aluminum with Acrylic front window
Finish	Standard: Powder coated off white finish.
Weight	Unit without mount: 15 lbs.

7.3 Environmental - Rated for Indoor Use Only

Operating Temperature	0 °C to +50 °C
Storage Temperature	-20 °C to +60 °C

7.4 Camera Specifications

7.4.1 Color High Resolution Camera

Horizontal Resolution	480 TVL
Voltage Range	22-26 VAC, 60 Hz
Power	3W
Sensitivity minimum scene illumination f/1.2 lens, 50 IRE	1.2 lux
Imager	1/4-inch Image Format; Interline Transfer CCD
System	NTSC
Signal to Noise	48dB
Electronic Shutter	1/50 (1/60 EIA) to 1/100,000
Backlight Compensation	Selectable On/Off Control
White Balance	Automatic Sensing through the Lens (TTL System): +2700 K to 9000 K.
Video Output	Composite; 1.0 Vp-p, 75ohm
Synchronization	DC Crystal-lock: (DC supplied or Line-Lock off)
Phase Adjust	0° to 330°
Controls	Line lock on/off; AWB on/off; AGC on/off; Gamma on/off; BLC on/off

7.4.2 Wide Dynamic Range (WDR)

Horizontal Resolution	480 TVL
Voltage Range	22-26 VAC, 60 Hz
Power	3W
Sensitivity	0.5 lux
minimum scene illumination	(30 IRE)
f/1.2 lens, 50 IRE	
Imager	1/3-inch Image Format; Interline Transfer CCD
System	NTSC
Signal to Noise	50dB
Electronic Shutter	1/50 (1/60 EIA) to 1/100,000
Backlight Compensation	Yes
White Balance	Automatic Sensing through the Lens (TTL System): +2700 K to 9000 K.
Video Output	Composite; 1.0Vp-p, 75ohm
Synchronization	DC Crystal-lock: (DC supplied or Line-Lock off)
Phase Adjust	0° to 330°
Controls	WDR on/off;

7.5 Lens Specifications

7.5.1 Color High Resolution version only

Option	Focal Range	Iris Range	Iris/Shutter	Format
-24	2-4mm	f/1.6 - 200	DC Auto Iris	1/3-inch
-36	3-6mm	f/1.2 - 360	DC Auto Iris	1/4-inch
-210	2.8-10mm	f/1.2 - 360	DC Auto Iris	1/4-inch

7.5.2 Wide Dynamic Range version only

Option	Focal Range	Iris Range	Iris/Shutter	Format
-39	3.8-9.5mm	f/1.3 - 360	DC Auto Iris	1/3-inch

8. PVD ACCESSORIES

8.1 Power Supplies

Part Number	Description
PS-24VA4A	Power Supply that converts 120V to 24VAC, 4Amp output, includes 6 foot power cord.
PS-24VA4A-PB	Power Supply that converts 120V to 24VAC, 4Amp output, includes 6 foot power cord and plenum box.
PS-28VA4.6A-PB	Power Supply that converts 120V to 26VAC, 3.8Amp output, includes 6 foot power cord and plenum box for use with long cable runs.

8.2 Mounting Options

Part Number	Description
MTFPW	Wall Bracket With Vesa Plate Pattern
MTFPWA-	Wall Bracket with Mount Adapter With Vesa Plate Pattern
MTFPPO-	Pole Clamp for use with the MTFPW
MTFPF10P-	Feed-thru Pole Mount with Pipe Coupling
MTFPF12F-	Pole Mount with Surface Flange Coupling (For Wall or Ceiling)
2x2CPTC	2' x 2' Aluminum Ceiling Panel with 1 1/2" pipe coupling
MTJ-	Joist Mount

8.3 Sign Hanging Hardware Kit - Optional

Part Number	Description
Call Factory	2 Eye bolts and 1 chain set. Hardware kit that when installed, allows signage to be hung below the unit.

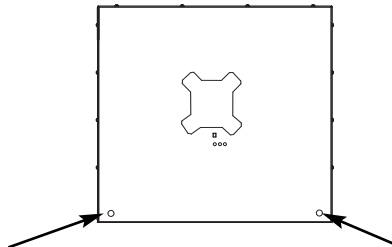

Two predrilled holes are located where the arrows are pointing on the back of the PVD20. Use these holes to install the sign hanging kit.

9. REPLACEMENT PARTS

Part Number	Description
315 5431 001	Camera Replacement Kit: 1 color high resolution camera with 3-6mm lens
315 5431 002	Camera Replacement Kit: 1 wide dynamic camera with 3.8-9.5mm lens

10. DIMENSIONAL OUTLINE

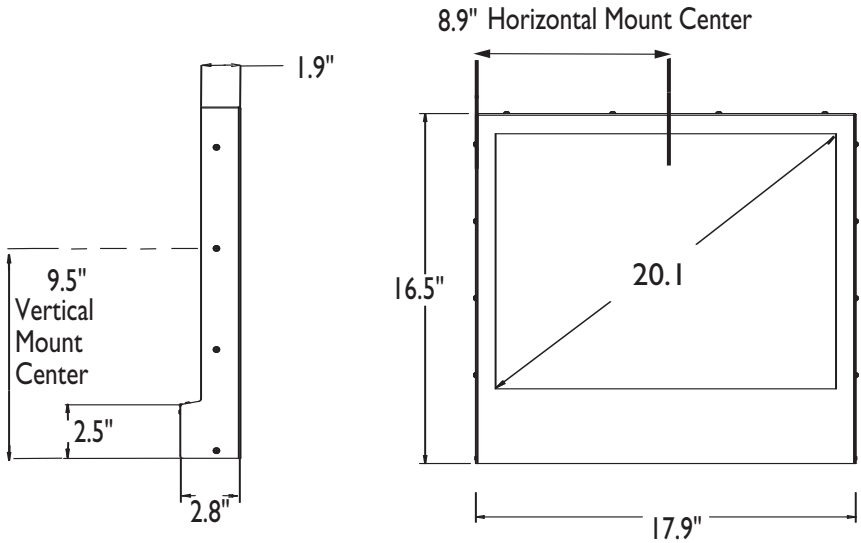

©2005 Aigis Mechtronics

1124 Louise Road, Winston-Salem, NC 27107-5450

Tel: 336.785.7740 Fax: 336.785.7744

100 0169 001 AIG 02/06

Printed in U.S.A.

Data subject to change without notice