

**FULL HEIGHT
ALUMINUM TURNSTILE
SINGLE UNIT**



AT-FAL SERIES

SAFETY PRECAUTIONS



**CAUTION: TO REDUCE RISK OF ELECTRICAL SHOCK,
DO NOT SERVICE WITH THE POWER ON.
REFER SERVICING TO QUALIFIED SERVICE PERSONNEL.**

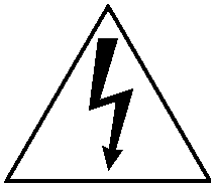

The lightning flash with an arrowhead symbol within an equilateral triangle is intended to alert the user to the presence of uninsulated "dangerous voltage" within the product's enclosure that may be of sufficient magnitude to constitute a risk of electric shock to persons.



The exclamation point within an equilateral triangle is intended to alert the user to presence of important operating and maintenance (servicing) instructions in the literature accompanying the appliance.

**WARNING: TO PREVENT FIRE OR SHOCK HAZARD,
DO NOT EXPOSE THE INSIDE OF THE HEADER
TO RAIN OR EXCESSIVE MOISTURE.**



Attention: Qualified personnel only in accordance with the National Electrical Code or applicable local codes should perform installation and servicing.

**WARNING: 120 VOLT POWER MUST BE OF AMPLE
SUPPLY FOR OPERATIONG THIS EQUIPMENT SAFELY AND IT MUST BE
PROPERLY GROUNDED.**

2 EXPLODED VIEW DRAWING (EVD)

NOTE: Where there are multiple identical parts, only one of each is shown on this drawing for clarity.

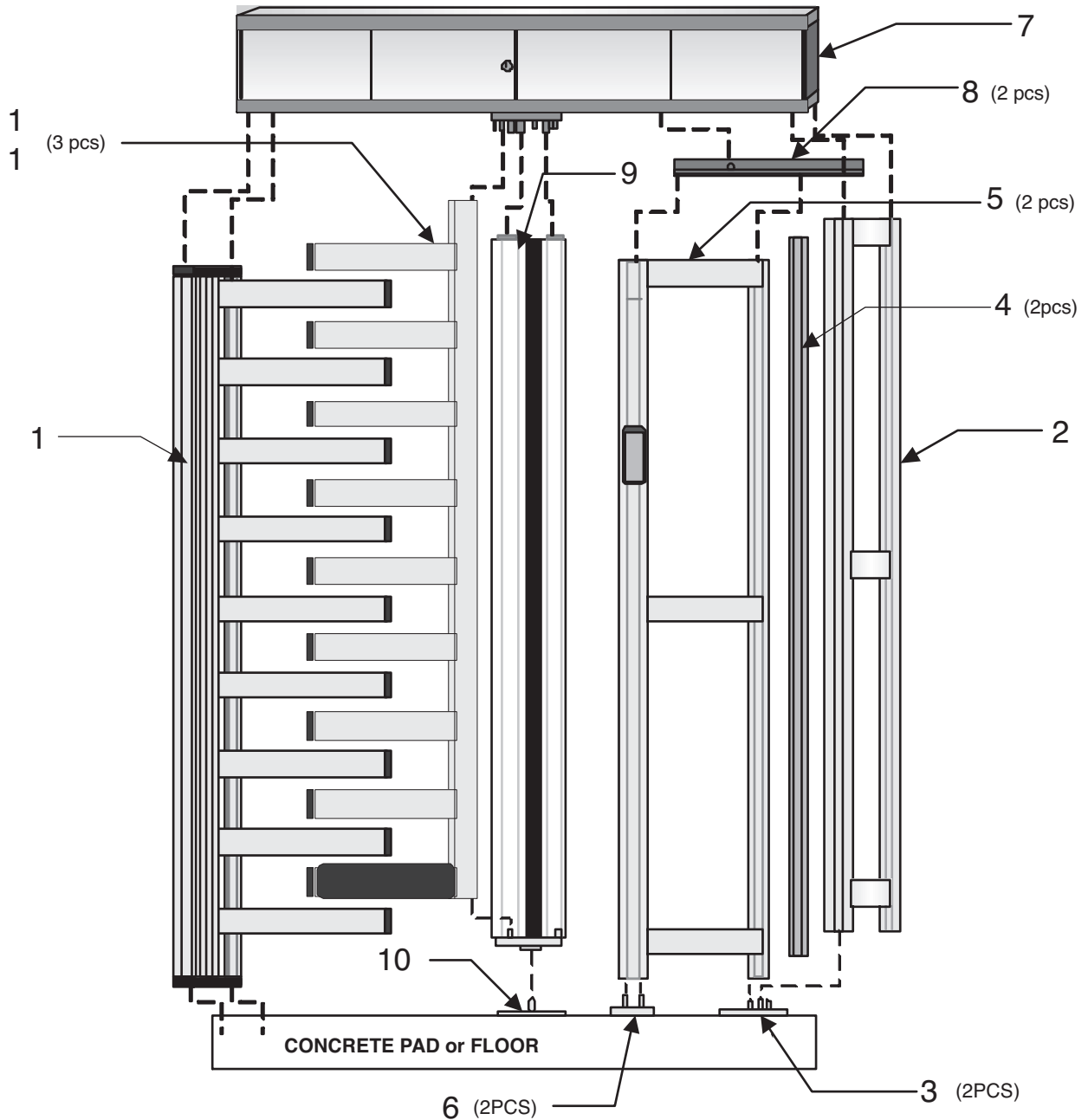

- 1 - BARRIER ASSEMBLY
- 2 - CENTER PASSAGE PANEL
- 3 - CPP MOUNTING PLATE
- 4 - ANGLE ALIGNMENT EXTRUSION
- 5 - END PASSAGE PANEL
- 6 - EPP MOUNTING PLATE

- 7 - HEADER / MECHANISM ASSEMBLY
- 8 - CEILING PLATE
- 9 - CENTER COLUMN
- 10 - CC MOUNTING PLATE
- 11 - SPINDLE ARM ASSEMBLY

3 UNPACKING

The Turnstile is packaged to allow the installer to work out of the crate as the installation progresses.

Check to insure that the following parts are included for the applicable turnstile ordered:

NOTE: The following list is shown in the order that they will be required for installation.

1 BOX MOUNTING AND INSTALLATION HARDWARE		
Quantity	Description	Part # on Drawing
2	CPP Mounting Plate	3
2	EPP Mounting Plate	6
1	CC Mounting Plate	10
8	3/8" X 3-3/4" Anchor Bolt w/ Washer and Nut	N/A
4	5/16-18 X 3/4" Header Mounting Bolt w/ Washer	N/A
12	5/16-18 X 3/4" Spindle Arm Assembly Bolt	N/A
12	Bolt Cover	N/A
12	1/2-13 X 3/4" Ceiling Plate Bolt	N/A
2	1/4-20 Nylock Nut	N/A
4	Keys, Header Access	N/A

INDIVIDUALLY WRAPPED COMPONENTS		
Quantity	Description	Part # on Drawing
1	Barrier Assembly	1
1	Center Passage Panel (CPP)	2
2	Angle Extrusion	4
2	End Passage Panel (EPP)	5
1	Header & Mechanism	7
1	Center Column (CC)	9
2	Passageway Ceiling Panel	8
3	Spindle Arm Assembly	11

4 INSTALLATION

NOTE: FOLLOW THE INSTRUCTIONS CLOSELY. THE ORDER OF INSTALLATION AND ASSEMBLY IS CRITICAL TO A SUCCESSFUL INSTALLATION.

- **REMOVE AND POSITION THE BARRIER ASSEMBLY (PART #1 ON EVD)**

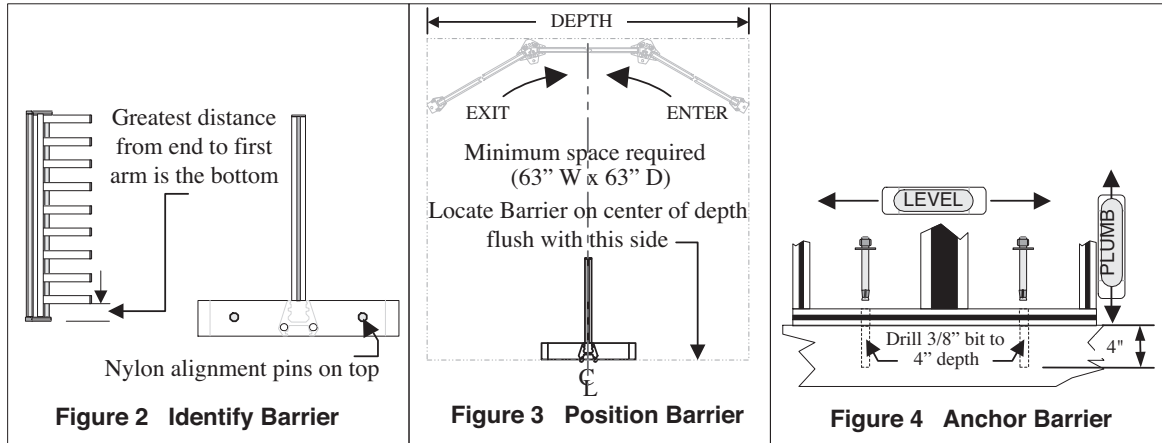

- Position Barrier in exact place to be installed.
- LEVEL AND PLUMB.
- Drill and set anchor bolts.

- **REMOVE THE CENTER PASSAGE PANEL (PART # 2 on EVD) AND THE TWO CPP MOUNTING PLATES (PART #3 on EVD)**

NOTE: The Center Passage Panel has a wire race outlet slot in the top horizontal member.

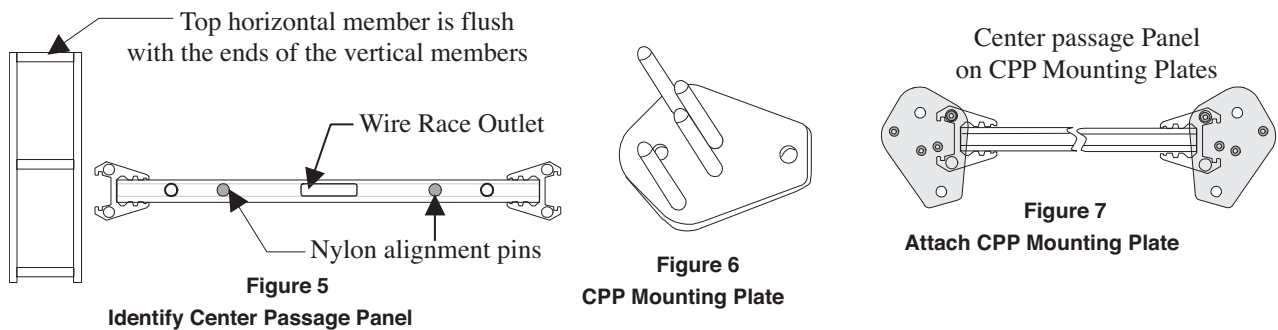

Position Center Passage Panel very close to where it will be anchored when the installation is finished.



CAUTION: During assembly of the passageway section one person should remain with the assembled sections to prevent the possibility of them falling over.

• **REMOVE AND ATTACH ONE ANGLE EXTRUSION (PART # 4 on EVD)**

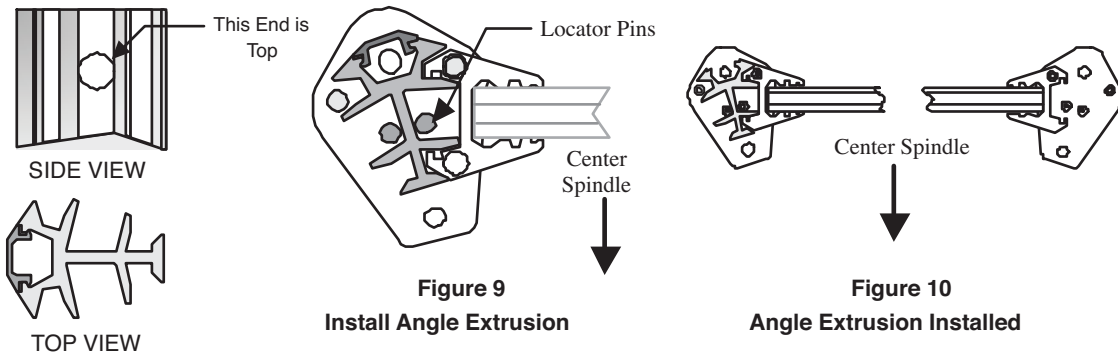

Figure 8
Identify Angle Extrusion

- Install the Angle Extrusion.

Lift the Angle Extrusion to just higher than the mounting plate pins. Insert it into the back of the center panel as shown and lower it down between the pins until it is flush with the top of the CPP Mounting Plate.

• **REMOVE AND ATTACH ONE END PASSAGE PANEL (PART #5 on EVD) AND EPP MOUNTING PLATE (PART #6 on EVD)**

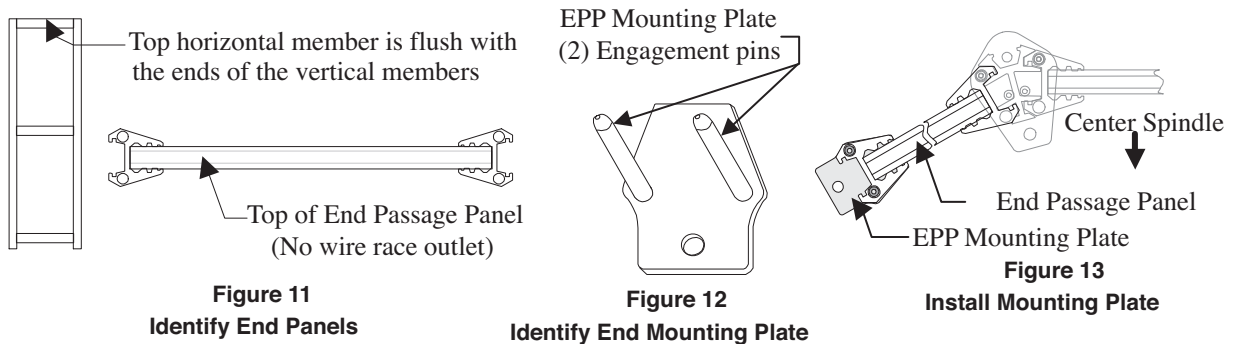

Figure 11
Identify End Panels

Figure 12
Identify End Mounting Plate

Figure 13
Install Mounting Plate

- Insert the engagement pins of the EPP Mounting Plate into the bottom vertical of End Passage Panel as shown .
- Lift the End Passage Panel and EPP Mounting Plate above the engagement pin of the CPP Mounting Plate.
- Engage the back slot of the End Passage Panel with the Angle Extrusion and slowly lower the panel onto the pin until it is flush with the top of the CPP Mounting Plate.

• **REMOVE AND ATTACH OPPOSITE SIDE ANGLE EXTRUSION (PART #4 on EVD), END PASSAGE PANEL (PART # 5 on EVD) AND EPP MOUNTING PLATE (PART #6 on EVD)**

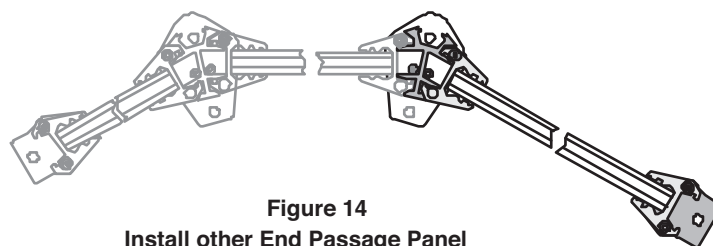
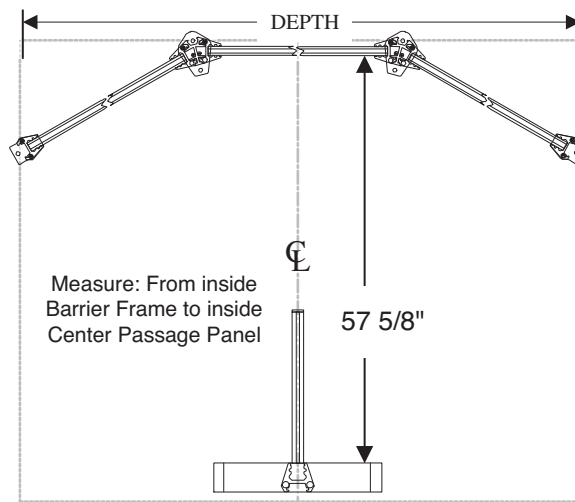

Figure 14
Install other End Passage Panel

- Install same way as other side.
- Verify location of Passage Panels before installation of header assembly.



CAUTION: Position passage panels only. DO NOT ANCHOR until instructed to do so later.

Figure 15 Locate Passage Panels

- The distance from the inside face of the barrier horizontal member and the inside face of the horizontal member of the center passageway panel should be 57-5/8".
- **REMOVE AND INSTALL THE HEADER / MECHANISM ASSEMBLY (PART # 7 on EVD)**

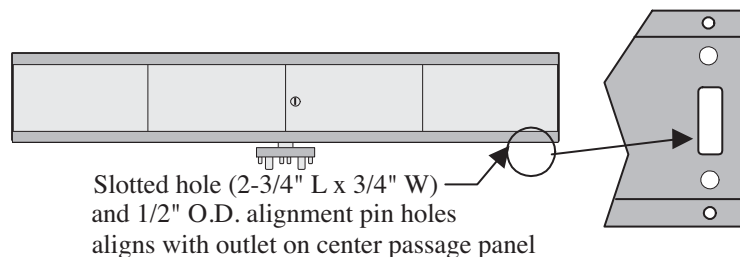

Figure 16a Header/Mechanism Identification

NOTE: Once the turnstile is fully assembled and anchored into place it will be necessary to secure the top of the unit to prevent excessive swaying when it is in use. If you need to drill holes into the ends or top of the Header/Mechanism to accomplish this, it may be easier to do that now while all surfaces of the header are accessible.

Also, now is a good time to prepare the header for conduit entry with power and control wiring.

See **ELECTRICAL CONNECTIONS** near the end of this section.

- Identify which end of the header sits above the passageway panels.
 - Look at the underside of the Header/Mechanism and find the end with a slotted hole in the sheet metal as shown in **Figure 16a**. This end sits on top of the Center Passage Panel.
- Lift the Header/Mechanism above the barrier and passageway panels and set it down over the nylon locator pins of the Barrier Assembly and Center Passage Panel.
- Secure the Header/Mechanism to the Center Passage Panel and Barrier Assembly using the 5/16-18 x 3/4" bolts and washers provided.

NOTE: To gain access to the inside ends of the header cabinet;

1. Unlock the center door panels and slide them open as far as they will go.
2. Near the bottom of the door there is a rod with a knurl knob nut, rotate the nut toward the inside of the cabinet.
3. This will release the end door panels allowing you to slide them toward the center and access the mounting holes.

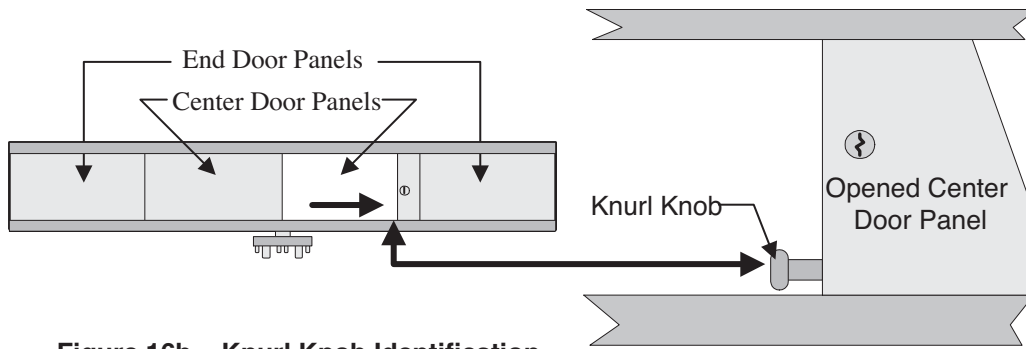

Figure 16b Knurl Knob Identification

• ANCHOR THE CENTER PASSAGE PANEL

- LEVEL and PLUMB the Center Passage Panel and anchor into place. (Do not drill holes for the end passage panels yet.)
 - Note that the CPP Mounting Plates have two mounting holes each. Only one is needed to properly secure the panel.
 - For a cleaner looking installation the outside anchor hole, see illustration, should be used. However, if that location is not accessible for anchoring the inside hole can be used.

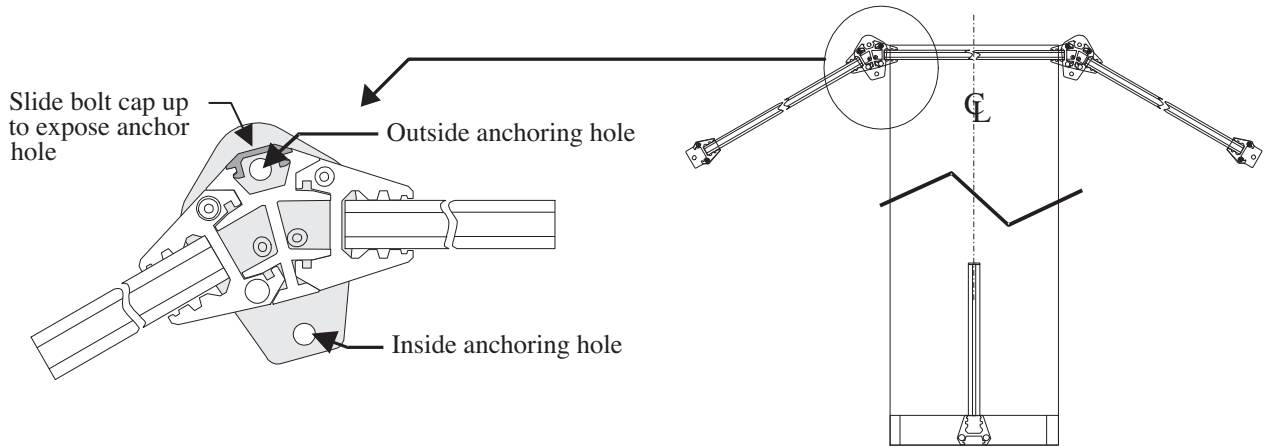

Figure 17 Anchor Passageway Panels

• PULL WIRES FOR THE STATUS INDICATOR LIGHTS

- Remove the Caps at the top of each End Passage Panel to expose the wire raceway.
- Rolled up inside the header on the passageway side are the wire cables for the status indicator lights.

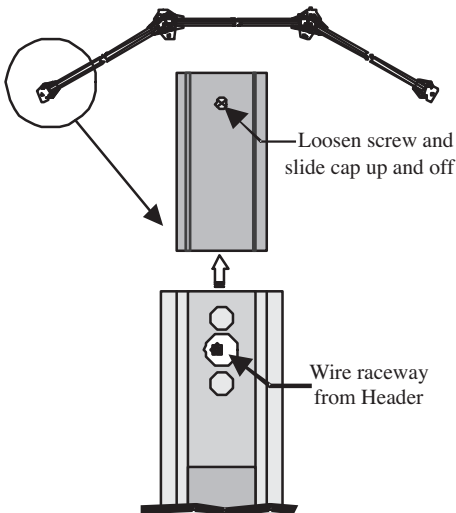

Figure 18 Wire Raceway

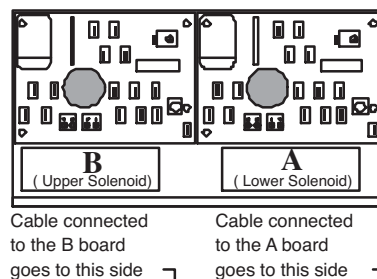

Figure 19 Cable Identification

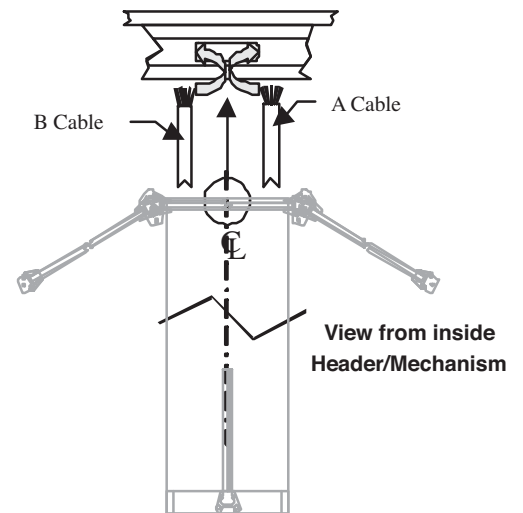

Figure 20 Cable Direction

• **ANCHOR THE CENTER PASSAGE PANEL**

- LEVEL and PLUMB the Center Passage Panel and anchor into place. (Do not drill holes for the end passage panels yet.)
 - Note that the CPP Mounting Plates have two mounting holes each. Only one is needed to properly secure the panel.
 - For a cleaner looking installation the outside anchor hole, see illustration, should be used. However, if that location is not accessible for anchoring the inside hole can be used.

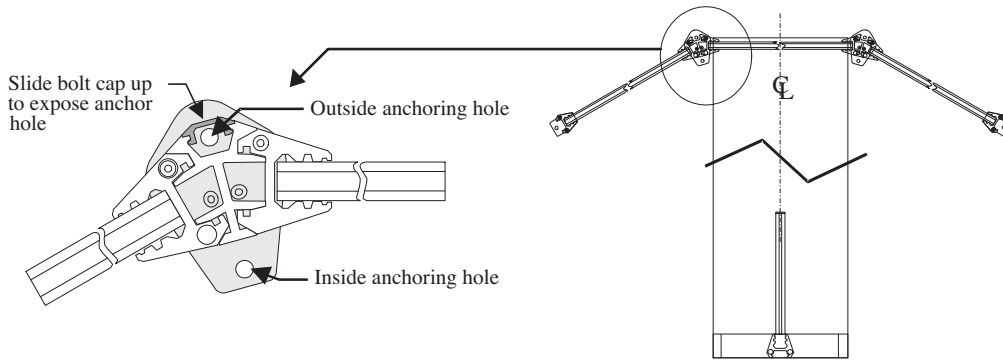

Figure 17 Anchor Passageway Panels

• **PULL WIRES FOR THE STATUS INDICATOR LIGHTS**

- Remove the Caps at the top of each End Passage Panel to expose the wire raceway.
- Rolled up inside the header on the passageway side are the wire cables for the status indicator lights.

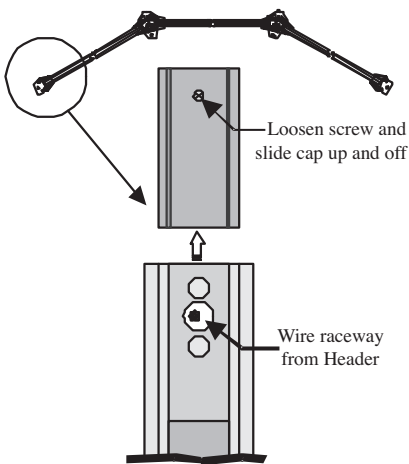

Figure 18 Wire Raceway

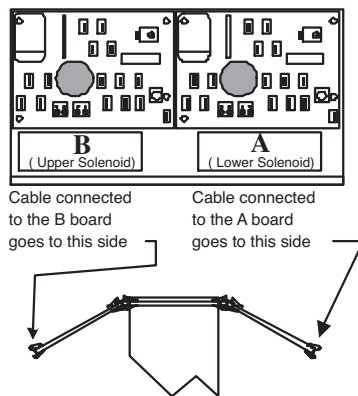

Figure 19 Cable Identification

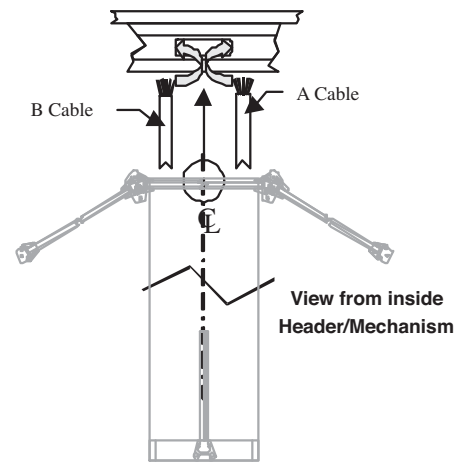

Figure 20 Cable Direction

- Starting from inside the Header/Mechanism, pull or push the appropriate cable to the status indicator lights to be wired as shown in **Figure 20**.
- Push the wire cable through the angle Extrusion as shown in **Figure 21**.

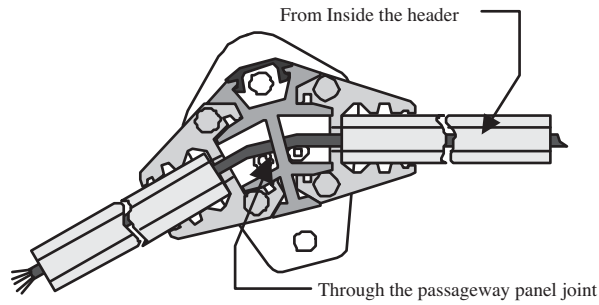

Figure 21
Push Cable Through

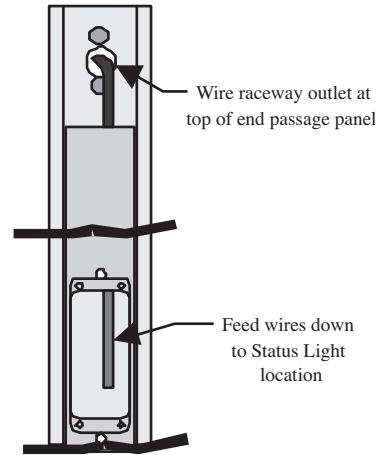

Figure 22
Cable Ending Point

- Push cable out of End Passageway Panel and feed down to Status Light location as shown in **Figure 22**.



CAUTION: Standard anti-static procedures should be observed when handling the Status Light Boards. It is recommended you ground yourself to the turnstile frame before handling the board. Remain in contact with the turnstile while handling the board.

- Remove the Status Light Cover using the #10-24 screws.
- Remove the Status Light assembly from the mullion using the #4-40 screws.
- Connect the wires to the terminal block on the Status Light Board as shown in **Figure 23**.

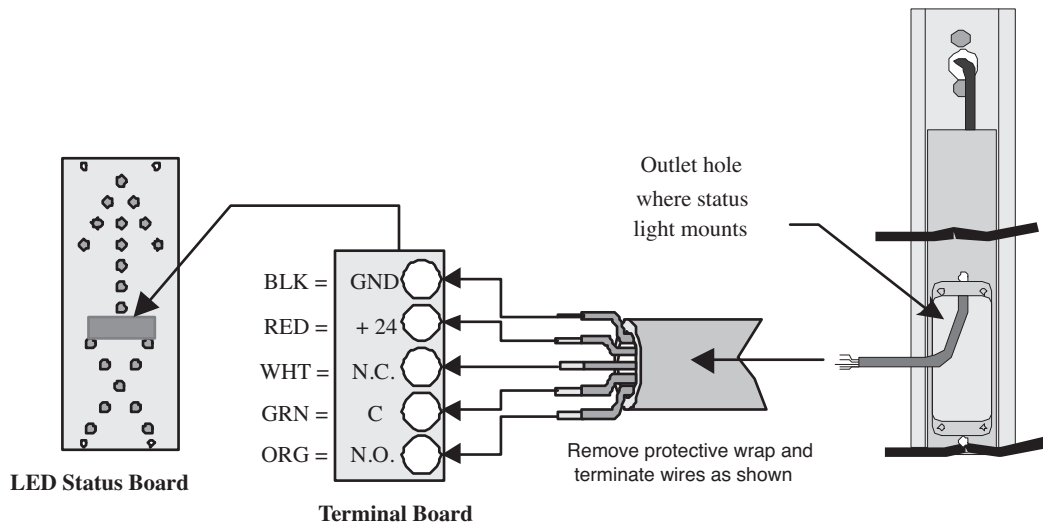

Figure 23
Status Light Wiring

- Attach the Status Light assembly to the mullion using the #4-40 screws.
- Install the Status Light Cover using the #10-24 screws.
- Reinstall the cap at the top of the End Panels.

- **INSTALL THE PASSAGEWAY CEILING PLATES (PART #7 on EVD)**

Note: The side of the ceiling plate with an edge protector will face toward the barrier.

- Slide the hole in the angle side of the plate over the threaded stud on the header and secure using the 1/4-20 nylock nut provided.

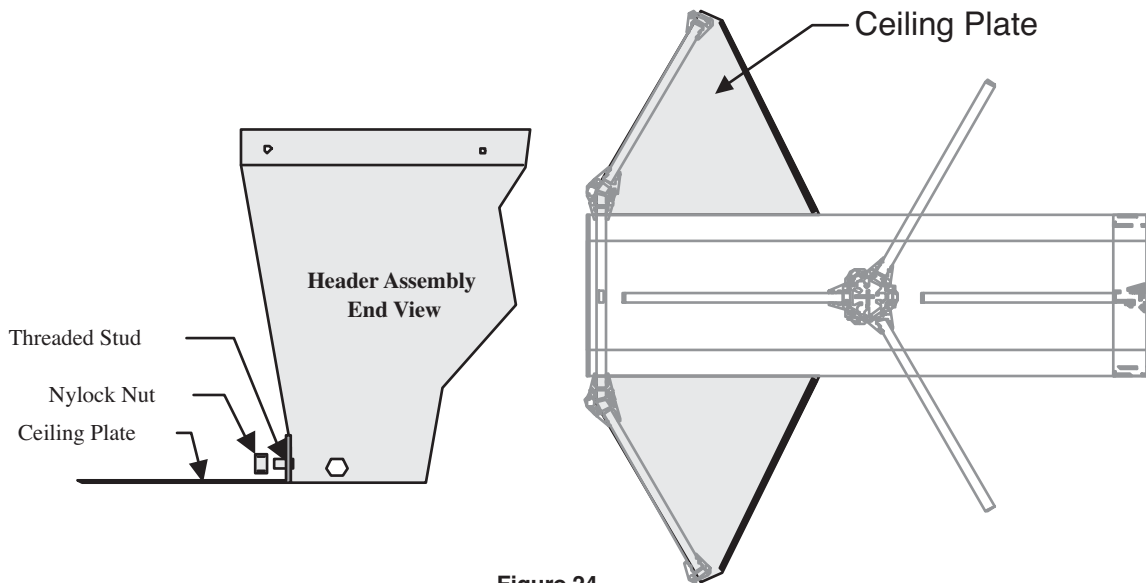

Figure 24
Attach Ceiling Plates

- Secure the Ceiling Plate to the passageway panels using the 1/2-13 x 3/4" bolts provided. (6 places)
- Repeat ceiling plate installation on opposite side of passageway.
- **ANCHOR THE END PASSAGEWAY PANELS**
 - **SQUARE and PLUMB** the End Panels and anchor into place.

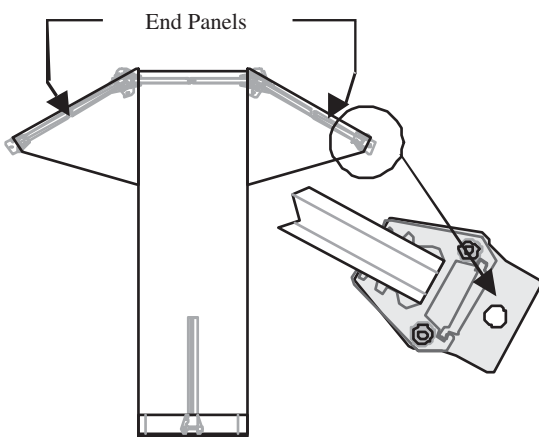

Figure 25
Anchor End Panels

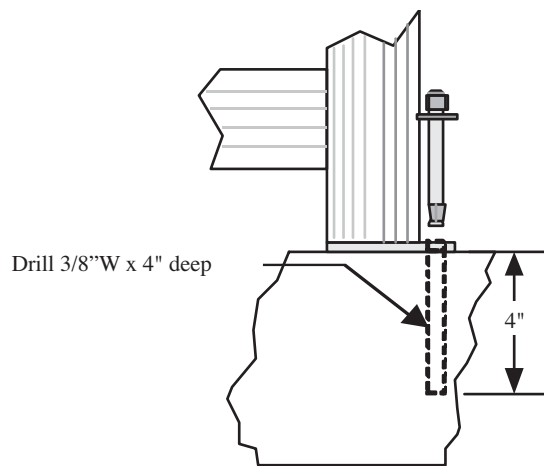

Figure 26
Drill and Set Anchors

• INSTALL CENTER COLUMN AND SPINDLE ARM ASSEMBLIES

- Lift the Operating Mechanism to the install position.

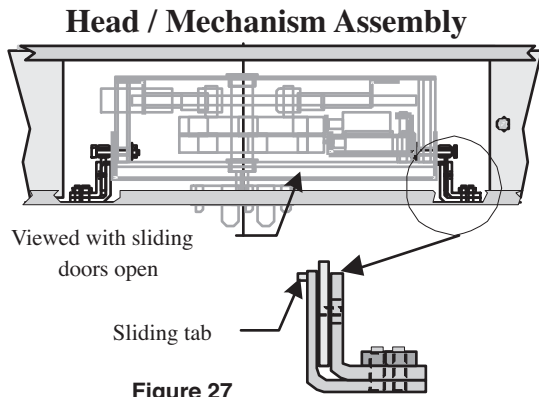

Figure 27
Raising the Mechanism

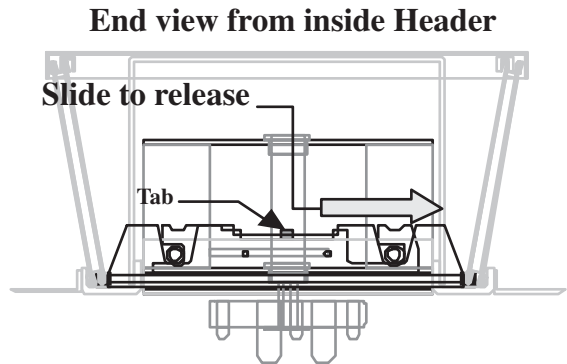

Figure 28
Release Mechanism Lock

- From inside the Header, slide the tab of the mechanism lock on both sides to release the mechanism.

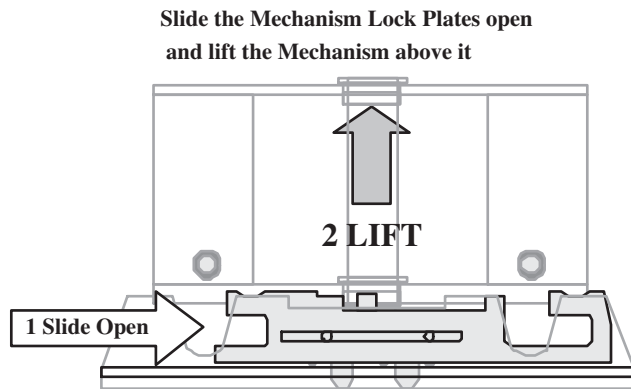

Figure 29
Release Lock and Raise Mechanism

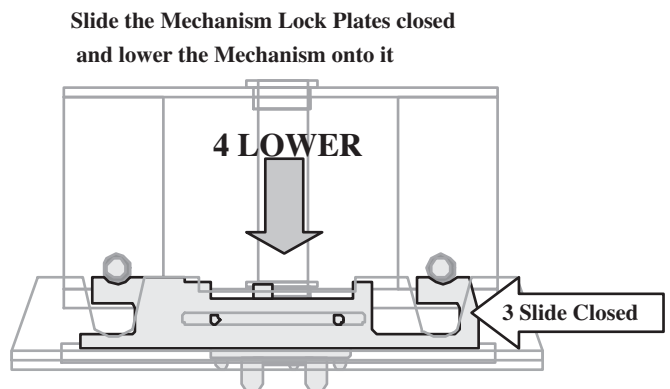

Figure 30
Place Mechanism on top of Lock

- From beneath lift the mechanism straight upward (two persons) until the slide bar tabs are accessible.
- Slide the tabs back to closed position and gently set the mechanism on it as shown in **Figure 30**.

• INSTALL CENTER COLUMN (PART #9 on EVD) and CC MOUNTING PLATE (PART #10 on EVD)

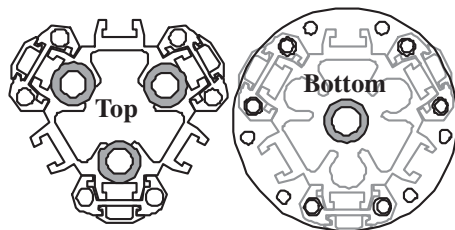

Figure 31
Identify Center Column

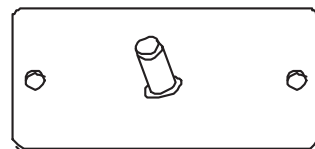

Figure 32
Identify CC Mounting Plate

- Insert the shaft of the CC Mounting Plate into the bearing on the bottom of the Center Column.
- Stand the Center Column up onto the CC Mounting Plate and position near the Mechanism Hub.
- Slide the Mechanism Hub up the Mechanism shaft until there is clearance for the Center Column to slide underneath.
- Slide the Center Column under the Hub, align the Center Column bushings with the large pins of the hub and slide the hub down the shaft engaging the pins into the bushings. There will be approximately 1/2" of engagement.

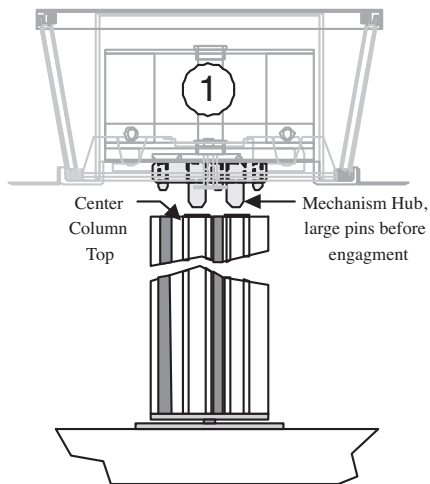

Figure 33
Position Center Column

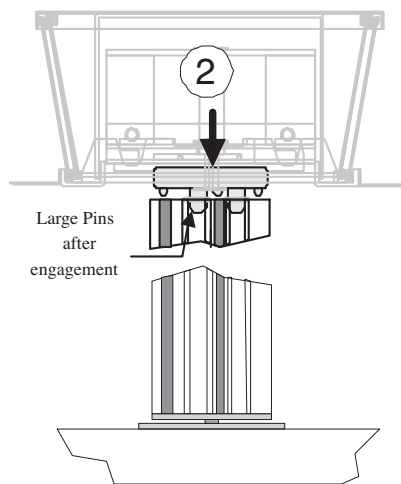

Figure 34
Engage Large Pins

• INSTALL THE SPINDLE ARM ASSEMBLIES

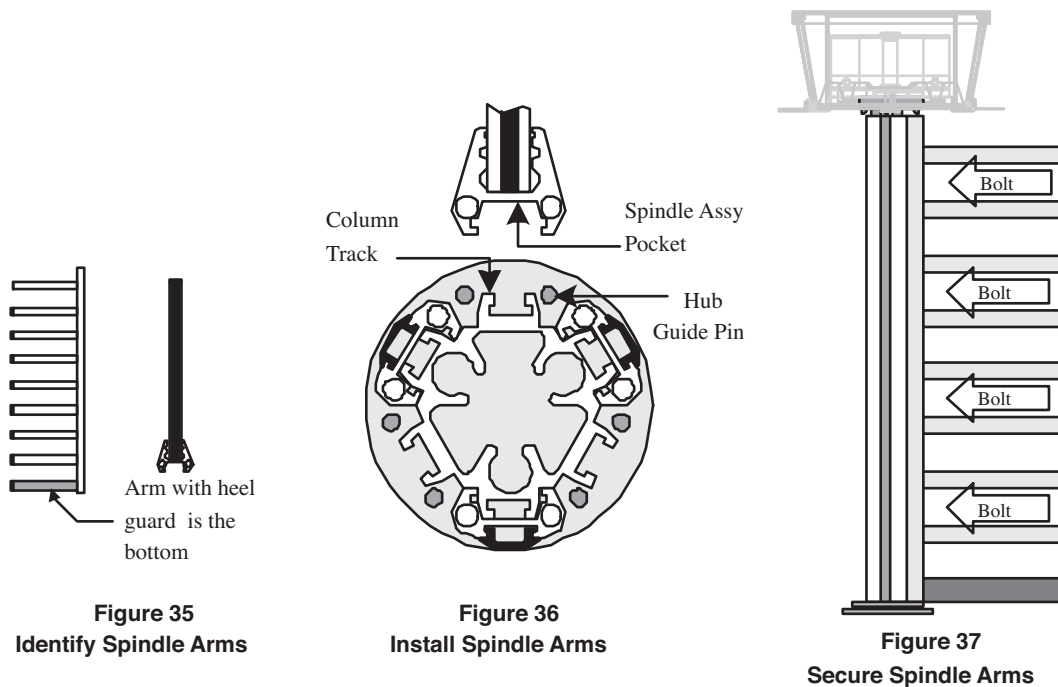

Figure 35
Identify Spindle Arms

Figure 36
Install Spindle Arms

Figure 37
Secure Spindle Arms

- Lift one of the Spindle Arm Assemblies to just above the guide pins on the Bottom Hub of the Center Spindle Column.
- Engage the back pocket of the Spindle Arm Assembly onto the Center Column Track.
- Lower the Spindle Arm Assembly onto the Hub Guide Pins.
- Hold the Spindle Arm Assembly tight against the Center Column and bolt into place.
- Use the 5/16 – 18 x 3/4” bolts provided. Place bolts in all 4 locations as indicated by the arrows, do not fully tighten yet.
- Bolting the top first will hold the Arm Assembly in place while the remaining bolts are being installed.
- Repeat steps for the remaining two Spindle Arm Assemblies.
- Lower and lock down the mechanism.



CAUTION: When lifting the mechanism to slide the tab for receiving, do not lift too high because the hub will disengage the center column.

- Lower the mechanism in the reverse manor of when it was lifted.

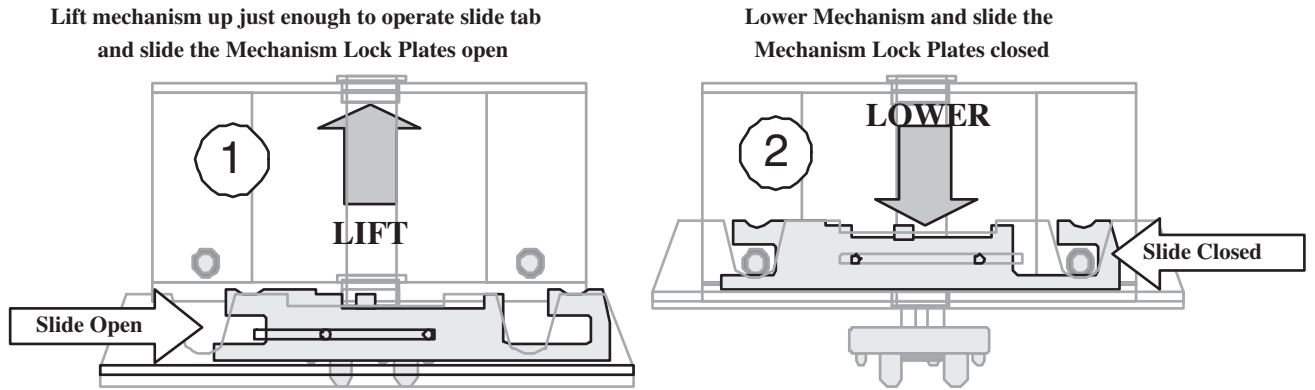

Figure 38
Lower Mechanism and Lock

- Insure that all the pins in the Hub are fully engaged into the Center Column and Spindle Arm Assemblies.
 - Slide the mechanism lock plates to the locked position.
 - Tighten all 12 bolts used to secure the three arm assemblies.
- **SQUARE, PLUMB** and Anchor the Center Column
 - **SQUARE** and **PLUMB** the Center Column (**Figure 39**).
 - Anchor the Center Column (**Figure 39**).

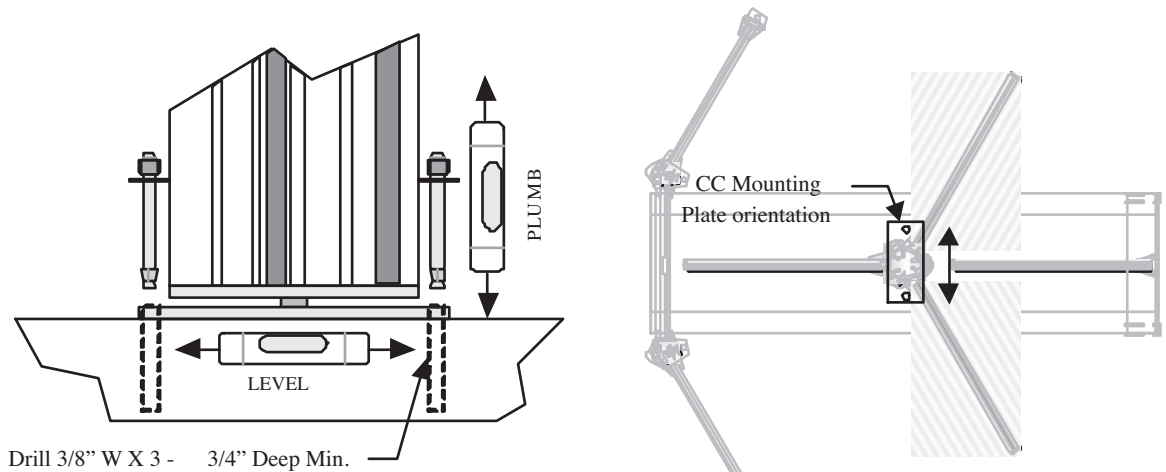

Figure 39
Anchor the Center Column

• **INSTALL THE BOLT COVERS**

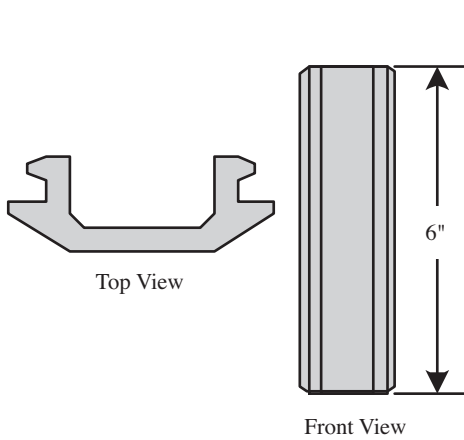

Figure 40
Bolt Cover

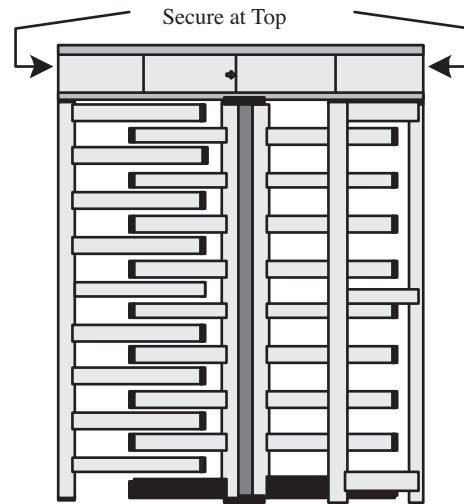

Figure 41
Secure Turnstile at Top

Use a rubber faced mallet and install one cap over all (12 places) of the spindle arm bolts.

- Secure to top of the turnstile to prevent top sway.
- **The mechanical part of the installation is completed.**

ELECTRICAL CONNECTION:

- 120 VAC power connection
 - Power for the turnstile must come into the header cabinet. Depending on the requirements of the site, it can either come in from the top or from one end of the cabinet.
 - Where there are multiple turnstiles in a row it may be necessary to pass through from turnstile to turnstile with the power and control wires.

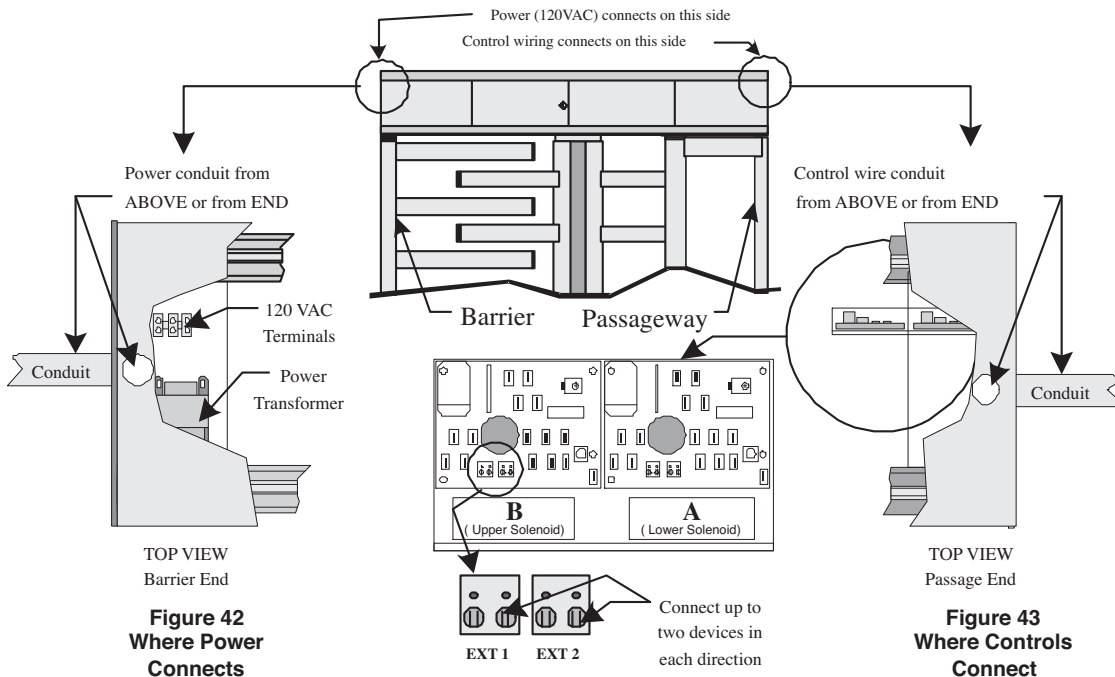

Figure 42
Where Power Connects

Figure 43
Where Controls Connect



CAUTION: When drilling into cabinet do not allow metal chips to fall on or near electrical components. Collect all chips and insure area is clean before applying power.

- Use watertight connections where entering the cabinet with conduit.
- Connect power to terminal block as labeled.



CAUTION: Standard anti-static procedures should be observed when handling the Turnstile Control Boards. It is recommended you ground yourself to the turnstile frame before handling the board. Remain in contact with the turnstile while handling the board.

- Connect card reader, pushbutton or other control contacts to either EXT1 or EXT2.
 - Access control devices (Card Readers, Pushbuttons, etc.) must provide a momentary dry contact closure of 1 second or less to activate the turnstile for one pass.

5 FUNCTIONAL TEST

1 With all electrical connections made, turn power on and perform a functional test of the turnstile.

2 When power is applied the turnstile center spindle arms should be locked. Try to rotate the arms in either direction. They should not rotate!

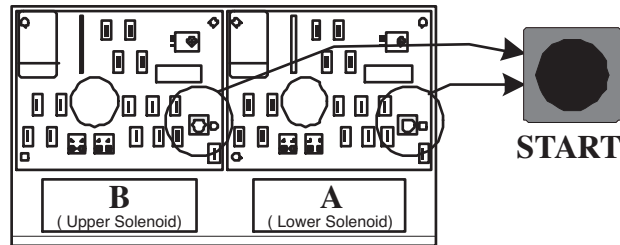

Figure 44
Start Button Location

3 TEST ROTATION

- On the control board of the direction of rotation to be tested first, push the START button.
- The solenoid that controls the direction being tested will release the locking pawl from the ratchet and allow the spindle arms to rotate.
- Push the turnstile arm sections in that direction, they should rotate for one cycle (120 degrees) and then re-lock automatically.
- Repeat a minimum of three times in each direction of rotation being tested.

4 TEST RELOCK TIMER

- Push the START button and the solenoid will activate the locking pawl. Wait ten seconds and the solenoid will de-activate the locking pawl.
- Push the START button and the solenoid will activate the locking pawl. Rotate the spindle arms approximately 10 degrees and hold in that position for more than 10 seconds, the solenoid will continue to activate the locking pawl.

5 TEST THE CENTERING MECHANISM

- Push the START button and rotate the spindle arms to just past mid-cycle. Stop the arms there and release them. They should rotate on their own and finish the cycle to the home position.

6 TEST THE ACCESS CONTROL DEVICE(S)

- Repeat the steps in number four above except use the access control device (Card Reader, Pushbutton, etc.) instead of the START button on the controller.

7 VERIFY THE STATUS LIGHTS ARE FUNCTIONING

- Verify that the red X status light is on before presenting the card.
- Present the card, the red X status light will turn off and the green arrow status light will turn on.
- Rotate the spindle arms to just past mid-cycle and the green arrow status light will turn off and the red X status light turn back on.

8 CHANGE FROM FAIL SECURE TO FAIL SAFE or FAIL SAFE TO FAIL SECURE (IF REQUIRED)

SEE **Figure 45**

- Disconnect the solenoid linkage (A) from the Solenoid by pulling out solenoid pin (X).
- Rotate Solenoid to line up with solenoid linkage (B) and reconnect Solenoid using solenoid pin (X).
- Disconnect the Pawl load spring (C) from the pawl pin (Y).
- Reconnect pawl load spring (C) to pawl pin (Z).
- On the Control Board that controls the Solenoid being changed, slide switch (S) to opposite position that it is in.

CONNECTION DIAGRAM: FULL HEIGHT SECURITY TURNSTILE

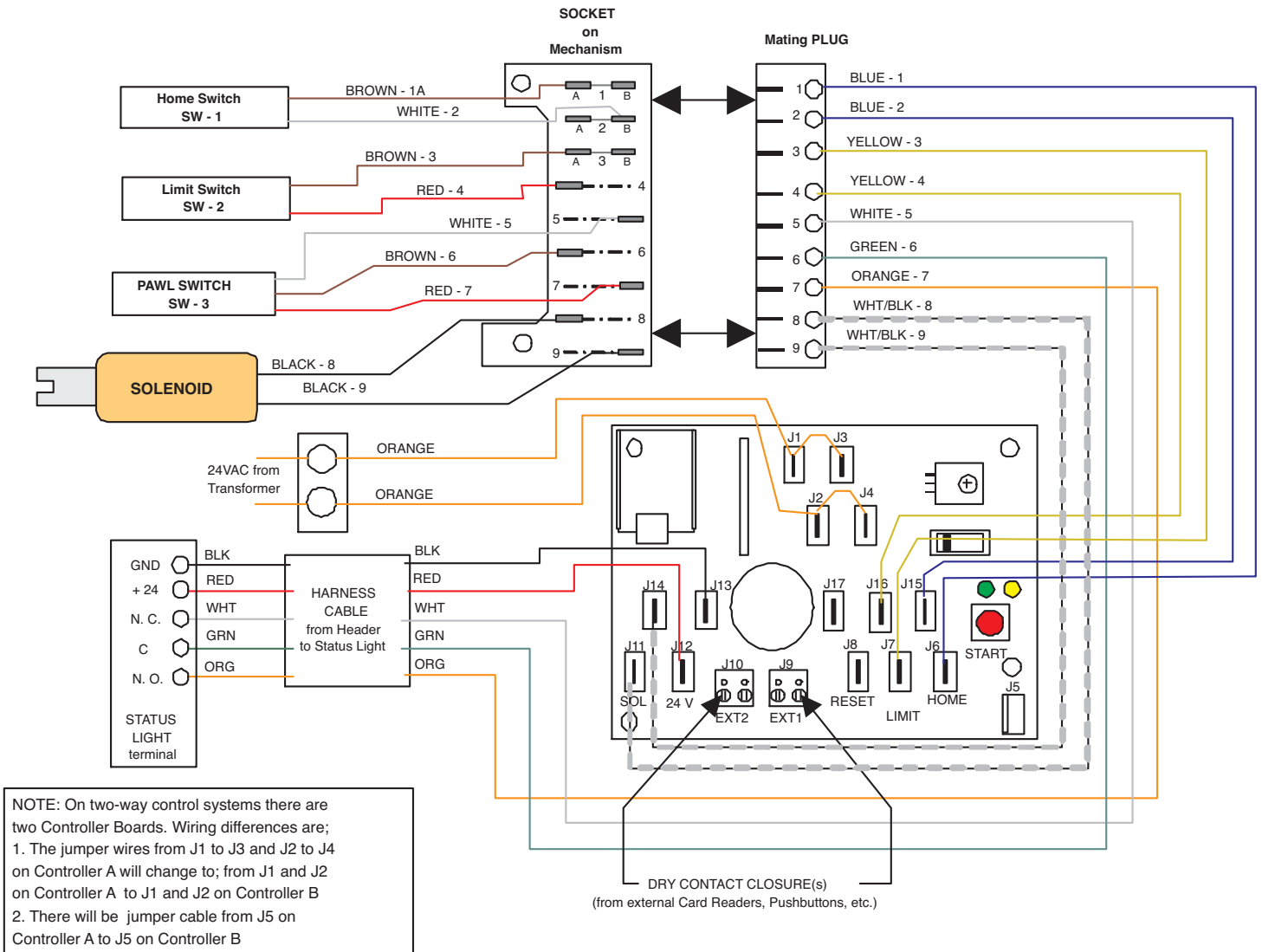

SERVICE AND MAINTENANCE

- All bearings are self-lubricating and do not require servicing or lubrication.
- Clean exterior aluminum and polycarbonate panel using a non-abrasive cloth with warm water and a mild detergent.
- Annually check solenoid plungers for wear. If excessive wear is observed replace solenoid.
- Annually check mechanism self-centering and speed control cylinder by observing while rotation the spindle section.
- Annually check for loose bolts or nuts.

MECHANISM PARTS

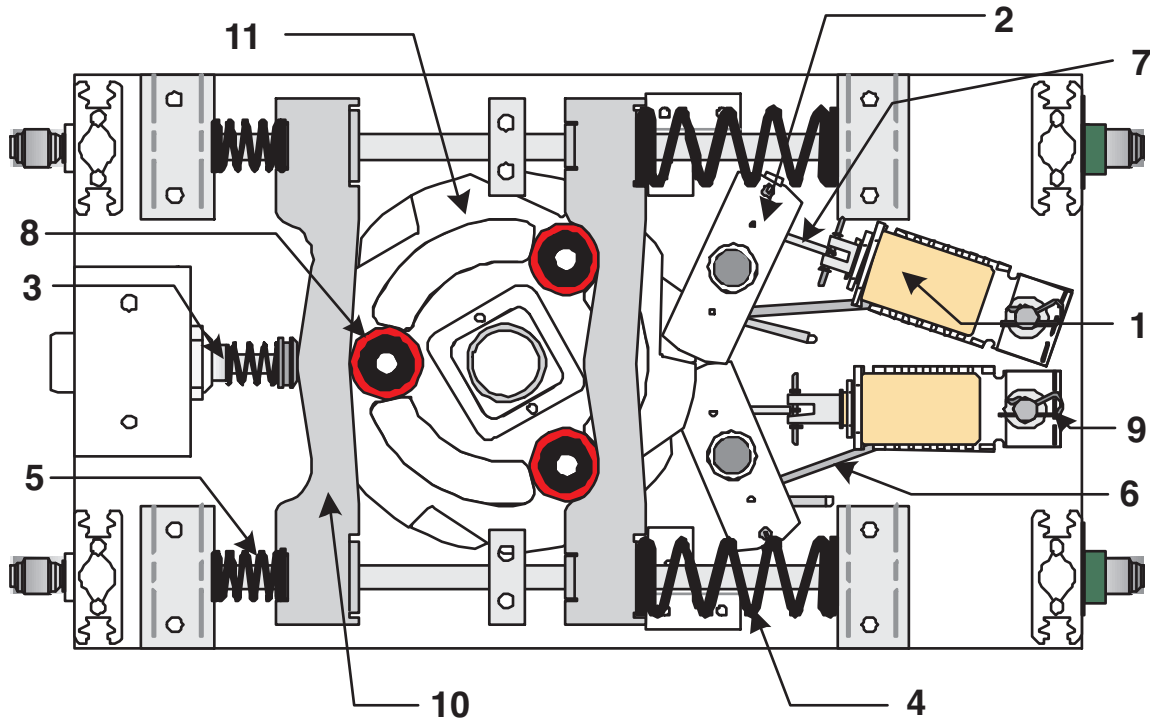

Figure 47
Mechanism Parts

Dwg #	Part Number	Description
1	315 4453 011	Solenoid Assembly
2	315 4383 001	Locking Pawl Assembly
3	315 4396 930	Detent Centering Spring
4	315 4396 940	Detent Shock Spring
5	315 4397 930	Pawl Return Spring
6	315 4397 920	Solenoid to Pawl Spring
7	315 4417 001	Detent Cam Roller
8	315 4420 900	Hitch Pin Clip
9	315 4455 011	Detent Cam Assembly
10	315 4530 500	Ratchet and Bushing Assembly



mechtronics
©2010 Aigis Mechtronics
1124 Louise Road, Winston-Salem, NC 27107-5450
Tel: 336.785.7740 Fax: 336.785.7744

100 0114 002 AIG 12/10

Data subject to change without notice.

Printed in U.S.A.